

• PROFESSIONAL SERVICE SPRAYER OWNERS GUIDE •

NON-CORROSIVE, POLYETHYLENE, COMPRESSED AIR SPRAYER

PLEASE READ AND FOLLOW ALL INSTRUCTIONS BEFORE USING SPRAYER

WARNING

Always inspect your sprayer thoroughly before each use. Be sure hose is securely attached and in good condition before pressurizing tank. Test with water at beginning of each season.

Always follow directions on spray material containers. Read them thoroughly and follow carefully.

Always wear such protective clothing (goggles, face masks, long sleeves, long pants, gloves, etc.) when spraying as is recommended by the manufacturer of the spray material. Do not allow spray to reach people or animals.

Always release air pressure before removing pump or servicing sprayer in any way by pulling pressure relief valve knob out fully.

Do not use flammable materials in this sprayer, as this could cause the sprayer to explode.

Do not use mechanical devices to pressurize the tank. They can create excessive and dangerous pressure which could cause the tank to explode.

Do not stand over pressurized tank while using or pumping it.

Always securely tighten the pump. An improperly tightened pump could be forcibly ejected and cause serious injury.

Do not use solutions hotter than 105° F.

Do not pressurize sprayer until ready to use. Do not leave pressurized sprayer unattended.

Do not lift or carry sprayer by hose or extension rod.

Clean tank and valve thoroughly with soap and water after herbicides and other poisons have been used.

If nozzle clogs, do not force open with air pressure. Remove nozzle and clean with fine wire or toothpick.

Read and follow all instructions in sprayer manual before using sprayer.

FAILURE TO HEED ALL SAFETY INSTRUCTIONS AND WARNINGS COULD RESULT IN SERIOUS BODILY INJURY.

HOW TO PREPARE YOUR SPRAYER FOR USE

1. To attach tank handle, align cutout slots on handle with vertical tabs at tank shoulder, push in and pull up on handle.
2. Assemble extension rod to valve by inserting and holding rod into open end of valve. Attach extension cap securely by hand.
NOTE: Never use tools to tighten connection nuts.
3. Remove pump assembly by engaging pump handle between lugs to turn cap off and on.
4. Mix spray solution in separate receptacle, following directions on spray solution container.
5. Strain solution through fine cheesecloth or household strainer to remove particles that could clog nozzle.
6. Use any amount of liquid up to the maximum Gallons/Liters line printed on the tank. **DO NOT** fill beyond this line.
7. Replace pump and cap assembly and tighten securely.
8. If sprayer has been stored, manually operate pressure relief valve by pulling knob out and pushing back in fully several times.
9. Pressurize tank by pumping approximately 15-25 times (depending upon amount of liquid used). * If a hissing sound through pressure relief valve is detected, sprayer is overpressurized. Quit pumping. Leave tank on a level surface until hissing stops. * As tank becomes pressurized, the knob of the pressure relief valve and gage will extend exposing a color band. This band indicates the maximum sprayer pressure operating range. (See Figures 1 and 2 on next page.)

HOW TO USE YOUR SPRAYER

1. Adjust nozzle cap. Tighten cap for fine spray or loosen for coarser spray or solid stream. **WARNING:** Loosening cap too far will result in cap flying off, allowing spray material to spray back at you.
2. Pump occasionally to maintain tank pressure and desired spray pattern. Pump when color band no longer shows.
3. The extension rod can be rotated 360°, turning counter-clockwise with extension rod pointed away from you.
4. Attach extension rod to handle by pushing it into the two clips provided.
5. Sprayer should only be carried by tank handle, pump handle, or strap (if provided). Never carry tank by the hose or discharge rod.

CLEANING AND MAINTENANCE INSTRUCTIONS

NOTE: A small amount of care will repay you in long life and efficient operation.

1. **RELEASE AIR PRESSURE** by pulling knob of pressure relief valve. Pull out fully and allow all air to escape. (See Figure 3).
2. Loosen cap slowly. Remove pump and cap assembly. Pour out any remaining spray solution and rinse all parts thoroughly with clean water.
3. Leaving a small amount of clean water in tank, pressurize and flush discharge equipment by depressing trigger approximately 30 seconds.
4. **RELEASE AIR PRESSURE** by pulling knob of pressure relief valve; remove cap and pump assembly. Rinse tank again and empty water.
5. To clean nozzle cap, refer to nozzle maintenance section.
6. Pull pressure relief valve knob out fully and rotate 90° to safety lock position. Tank cannot be pressurized with valve in this position.
7. Always store tank empty and with tank cap loose, upside down.
8. Apply approximately 10 drops of 20 weight or heavier motor oil in oil hole provided at top of tank cap before each growing season use and periodically there after.
9. If trigger is sluggish, remove extension rod assembly, depress trigger and apply 5 drops of oil in end of valve head.

PRESSURE RELIEF VALVE FUNCTION

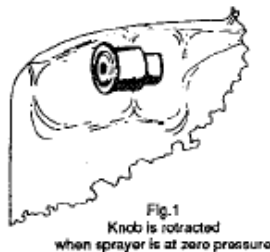
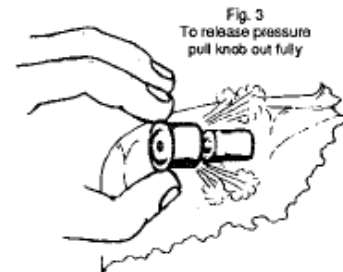
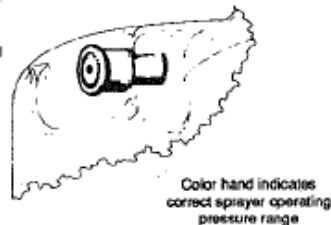

Fig. 2
Knob moves out as sprayer is pressurized



TROUBLE SHOOTING YOUR PLASTIC SPRAYER

PROBLEM: Sprayer Fails To Pressurize.

Step 1. Be sure tank cap is tight.

Step 2. Check to see if pressure relief valve is in safety lock position.

Step 3. Oil pump cup.

- Lift pump plunger and apply approximately 10 drops of 20 weight or heavier motor oil in hole provided in top of tank cap (A)
- Work plunger up and down.
- If sprayer will not pressurize, proceed to Step 4.

Step 4. Check pump assembly. SEE FIG. 4

- **RELEASE AIR PRESSURE.**
- Remove pump and tank cap assembly.
- Remove pump plunger by holding pump cylinder (B) firmly and pushing tank cap (A) up with thumbs to remove.
- Inspect cylinder gasket (D). If soiled, clean all surfaces of gasket and rim of tank with clean lint-free cloth. If split or worn, replace using parts from Kit R-30C (refer to back page).
- With pump still disassembled, inspect pump cup (E) for damage. If in good condition, wipe off any foreign particles. If damaged, replace using parts from Kit R-30C (refer to back page). Oil with 20 weight or heavier motor oil.
- Inspect check valve (F). If soiled, clean with lint-free cloth. If worn or split, replace using parts from Kit R-30C (refer to back page).
- Reassemble by starting plunger into pump cylinder at an angle. Replace cylinder into tank and tighten tank cap until cylinder and cap "snap" together and are tight.
- Oil pump cup following instructions in Step 3.
- If tank fails to retain pressure, proceed to the next sections to check for leaks.

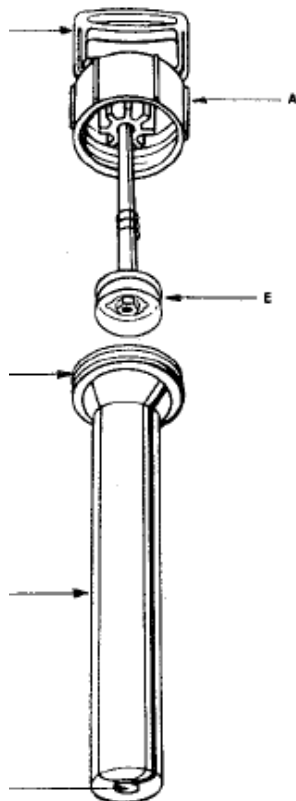

FIG. 4

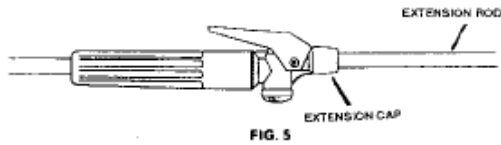

FIG. 5

PROBLEM: Sprayer Leaks. SEE FIG. 5

Step 1 Extension cap at extension rod.

- Tighten extension cap securely by hand.
- If leak persists. **RELEASE AIR PRESSURE**, remove rod by loosening extension cap and pulling rod straight out.
- If connection surfaces are scratched or damaged, replace using parts from Kit R-14C. (refer to back page)

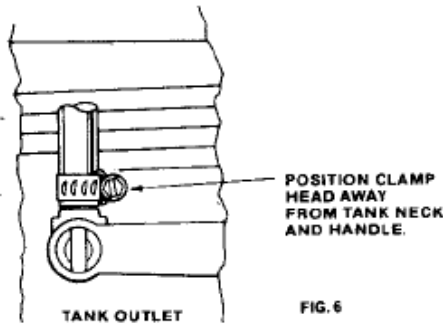

FIG. 6

Step 2. Hose at tank. SEE FIG 6.

- Release air pressure.
- Inspect hose, if split or worn, replace with parts from Kit R-51C. (NOTE: DO NOT ATTEMPT TO REUSE ORIGINAL FACTORY INSTALLED CRIMPED CLAMP).
- (a) Slide clamp on hose.
- (b) Holding end of hose under hot water for approximately 3 minutes will allow hose to slide on tank outlet easier.
- (c) Push hose fully onto tank outlet.
- (d) Slide clamp into position shown in FIG. 6.
- (e) Tighten clamp until a snug fit is obtained.
- Test for leakage by pressurizing with plain water.
- If leak persists tighten clamp until it stops.

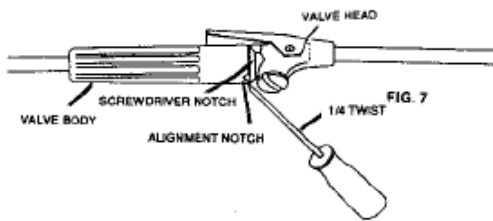

FIG. 7

Step 3. Where hose enters valve body

- Insert small blade screw driver into notch and twist ¼ turn to separate valve body from valve head. SEE FIG. 7
- Slide valve body back along hose to expose connection of hose with valve head. SEE FIG. 8
- Plastic sleeve must be tight on hose, if not grip sleeve firmly with thumb and forefinger and push toward end of hose until snug.
- If leakage is due to cracked or damaged hose, cut off behind sleeve, remove sleeve with pliers as shown then cut remaining hose off valve head hose fitting. SEE FIG. 9
- To reassemble.
 - (a) Slide plastic sleeve over hose (larger end of tapered sleeve toward end of hose.) SEE FIG. 8
 - (b) Push hose fully on valve head fitting (soaking end of hose in hot water first will make this operation much easier.)
 - (c) Push sleeve snugly on hose as described above.
 - (d) Align valve body with valve head and snap together tightly. SEE FIG. 7

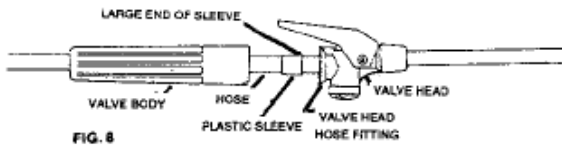

FIG. 8

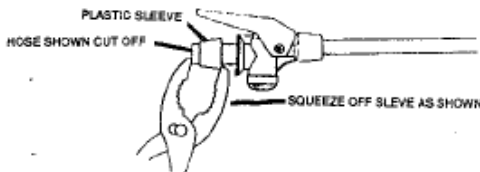

FIG. 9

Step 4. If leak is from any other area of valve, replace valve assembly using Kit R-58C.

PROBLEM: Sprayer Nozzle Does Not Spray or is missing.

Step 1. Clean nozzle.

- **RELEASE AIR PRESSURE.**
- Remove nozzle cap.
- Clean nozzle body (A) and cap orifice (B) using a toothpick or broom straw.
- Replace nozzle.

Step 2. Install new nozzle cap.

- If damaged or lost, replace using parts from Kit R-10C. (refer to back page).



FIG. 10

**TO ORDER REPLACEMENT
WANDS & TIPS**

Order #101P76HD for Comp. Wand
 Order #BP4FAN for Fanspray Tip w/Body
 Order #BP4ADJ for Adj. Spray Tip w/ Body

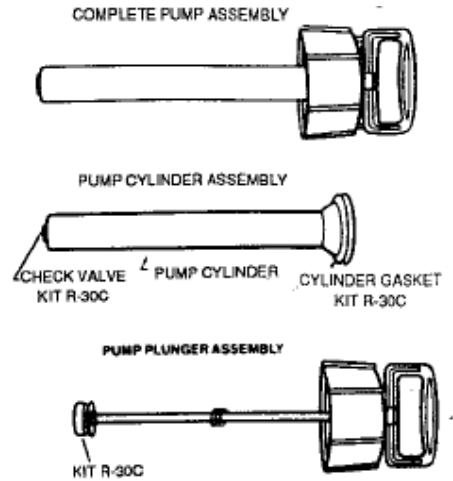
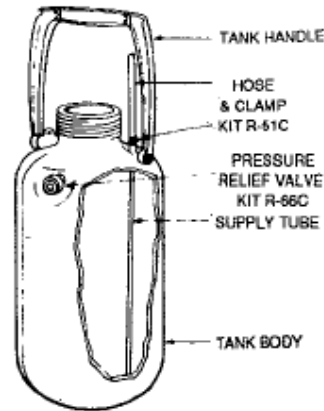

FOR REPAIR PARTS AND KITS
 CONTACT YOUR LOCAL
 DEALER
 or

Gilmour Manufacturing Co.
 P.O. Box 838
 Somerset, PA 15501-0838

(800) 852-2723

POLY VALVE & WAND:
 COMPLETE VALVE ASSEMBLY WITH
 HOSE, CLAMP & SLEEVE

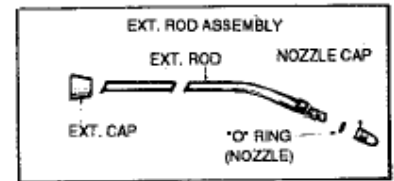
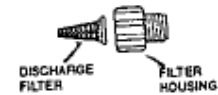
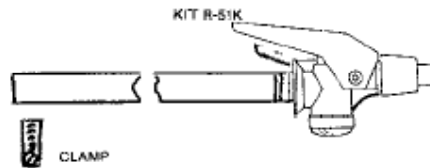

PROFESSIONAL POLY TANK SPRAYERS - Parts List

PART NAME	1 GAL. POLY WAND	3 GAL. POLY WAND	1 GAL. BRASS WAND	3 GAL. BRASS WAND
Pro Tank Body	100HD20R	300HD20R	100HD20R	300HD20A
Pro Tank Handle	10002LG	10002LG	10002LG	10002LG
Pro Pressure Relief Valve	R66CI	R66CI	R66CI	R66CI
Supply Tube	100024A	300024A	100024A	300024A
Complete Pump Assembly	100075I	100075I	100075I	100075I
Pump Plunger Assembly	100080	100080	100080	1000890
Pump Cylinder Assembly	100081	100081	100081	100081
Shoulder Strap	N/A	300050	N/A	300050
Pro Poly Valve & Hose Assembly	10070HD	10070HD	N/A	N/A
Pro Poly Wand	101P76HD	101P76HD	N/A	N/A
Poly Adj. Wand Tip	101P16	101P16	N/A	N/A
Pro Poly Filter Housing	300018HD	300018HD	N/A	N/A
Pro Poly Filter	300017	300017	N/A	N/A
Flat Spray Tip	100HD17	100HD17	100HD17	100HD17
Brass Valve Assembly	N/A	N/A	10070A	10070A
Brass Wand	N/A	N/A	30076	30076
Brass Wand Tip	N/A	N/A	R10C	R10C
Hose for Brass Valve	N/A	N/A	01030K	01030K
Clamp	10031HD	10031HD	10031HD	10031HD
Viton Check Valve	100026V	100026V	100026V	100026V
Viton Pump Cyl. Gasket	0R336V7A	0R336V7A	0R336V7A	0R336V7A